

STENVERKTYG

KIVITYÖKALUT

STONE WORKING TOOLS

WERKZEUGE FÜR DIE STEINBEARBEITUNG

**HERRAMIENTAS PROFESIONALES PARA
TRABAJAR LA PIEDRA**

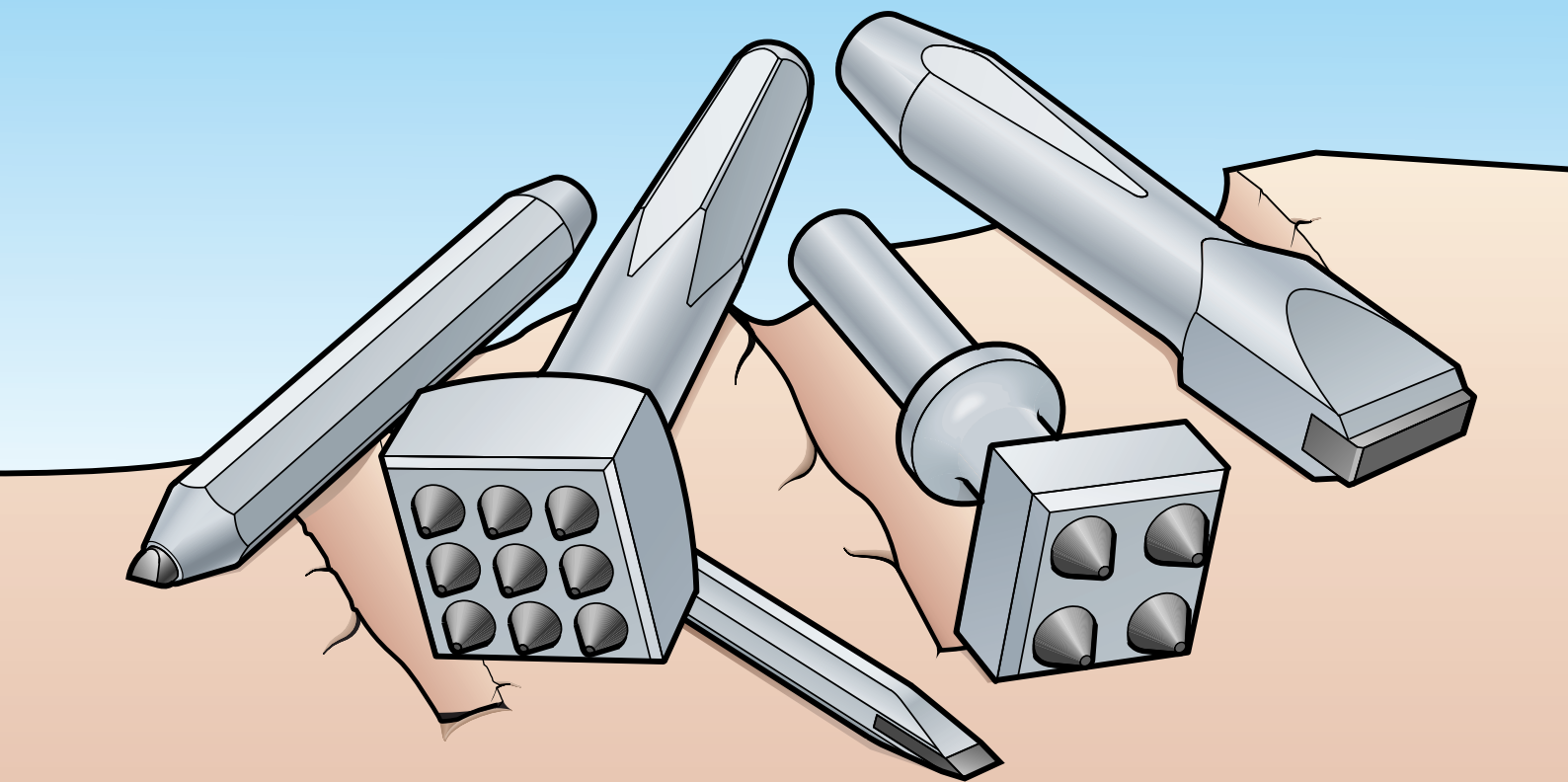

Rebit

Rebit

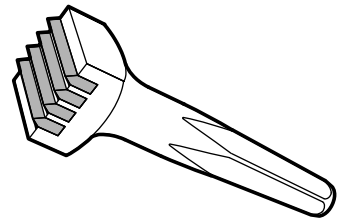
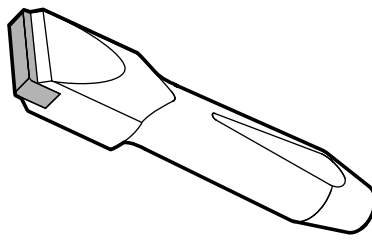

Rebit, ett bolag inom Atlas Copco koncernen, etablerades 1945. En ständig kvalitetsutveckling i nära samarbete med yrkesmän inom stenindustrin har gett REBIT-verktygen de speciella egenskaper som krävs för tuffa förhållanden.

Vårt sortiment täcker de flesta förekommande arbeten.

Skulle vi ändå inte ha vad Ni behöver ställer vi givetvis upp och hjälper till med speciella verktyg för just Ditt behov. Kontakta gärna vår marknadsavdelning!

Rebit, joka on osa Atlas Copco konsernia, perustettiin vuonna 1945. Jatkuva kehitystyö yhdessä kiviteollisuudessa työskentelevien ihmisten kanssa on antanut REBIT - työkaluille ne erikoisominaisuudet, joita "kovalla" alalla vaaditaan.









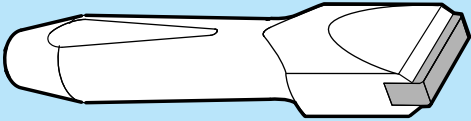

Laajasta tuotevalikoimastamme löydät työkalut useimpiin töihin. Jos kuitenkin tarvitset jotain erikoistyökälua, jota et tuoteluettelostamme löydä, ota yhteyttä omaan jälleenmyyjäsi niin katsotaan miten voimme Sinua auttaa.

Rebit, a subsidiary company of Atlas Copco, was established in 1945. A continuous quality development in close connection with the tradesmen in the stoneindustry has given the REBIT-tools the special properties that are needed for the tough conditions in that industry. Our range of tools covers most types of jobs. However, should you need something that you can not find in our catalogue please contact us for specials.

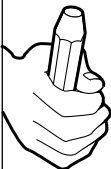
Rebit, ein Unternehmen im Atlas Copco-Konzern, wurde 1945 gegründet. Dank fortlaufender Qualitätsentwicklung in enger Zusammenarbeit mit Fachkräften in der Steinindustrie besitzen die REBIT - Werkzeuge die besonderen Eigenschaften, die für anspruchsvolle Arbeitsverhältnisse erforderlich sind.

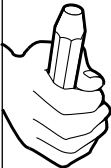
Unser Sortiment umfasst die meisten vorkommenden Arbeitsbereiche. Sollten wir dennoch nicht das vorrätig haben, was Sie benötigen, setzen Sie sich bitte mit uns in Verbindung. Wir helfen Ihnen gern mit Spezialwerkzeugen, die Ihren Bedürfnissen angepasst sind.

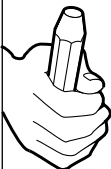
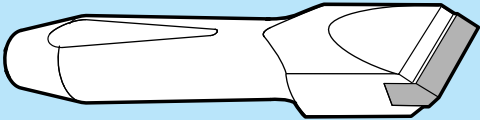
Rebit AB, fundada en 1945 es hoy una empresa del grupo Atlas Copco. Continuos desarrollos en los departamentos de calidad y en estrecha relación con nuestros clientes de la piedra, han dotado a las herramientas Rebit de las especiales propiedades necesarias para las más duras condiciones de trabajo. Sin embargo, si usted busca algo que no encuentra en nuestro catálogo, no dude en contactar con nosotros para herramientas especiales.

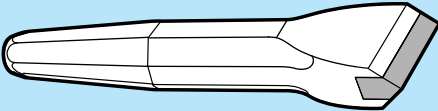
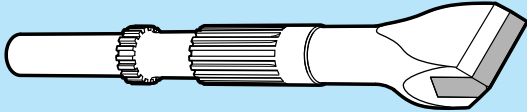
Kantj�rn, Ritsmejslar Kantiraudat, Piirtotaltat Chisels Meissel, Schlageisen Cinceles, Escalfiladores y Punteros	Artikelnr Artikkeli Ordering code Bestell Nr. Producto	Bredd Leveys Width Breite Anchura mm	L�ngd Pituus Length L�nge Longitud mm	St�ldim. Varsi Steelsize Stahlgr�sse Acero mm	Nackar Niska Shanks Schaftgr. Utilizaci�n
	SM40-O	40	190	� 40x30	
	SM40-R	40	190	33	
	SM40-H-F	40	245	� 25	
	SM20 SM25 SM40-HEX	20 25 40	150 150 190	� 12,7 � 12x22 � 25	
	RIM38-O	38	190	� 30x40	
	RIM38-R	38	190	33	
	RIM38-X	38	185	� 25	H
	RIM38-X	38	230	-	Q

Vid order ers tt X med nacktyp (se sid 8)











Tilauksen yhteydess  korvaa X niskatyypill  (katso sivu 8)

When ordering replace X by letter for shankgroup (see page 8)

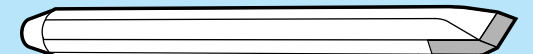
Bei Bestellung bitte das X durch den Buchstaben der Schaftgruppe ersetzen (Sishe 8)

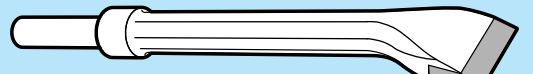
Para hacer su pedido reemplace la X por la letra correspondiente al grupo de bujes (ver pagina 8)

Rebit

Mejslar Taltat Chisels Meissels Cinceles, Punteros	Artikelnr Artikkeli Ordering code Bestell Nr. Producto	Breidd Leveys Width Breite Anchura mm	LŠngd Pituus Length LŠnge Longitud mm	StØeldim. Varsi Steelsize Stahlgrsŝe Acero mm	Nackar Niska Shanks Schaftgr. Utilizaci—n
	BM16K-X BM20K-X	16 20	220 220	Ø 15,9 Ø 15,9	A,D A,D
	BM16-X BM20-X	16 20	220 220	Ø 15,9 Ø 15,9	A,B,D A,B,D
	GM5-X GM8-X GM10-X GM12-X	5 8 10 12	220 220 220 220	Ø 12,7 Ø 12,7 Ø 12,7 Ø 12,7	A,B A,B A,B A,B
	GM5 GM8 GM10 GM12	5 8 10 12	170 170 170 170	Ø 12,7 Ø 12,7 Ø 12,7 Ø 12,7	
	HM12 HM16 HM20 HM25	12 16 20 25	185 185 190 190	Ø 15,9 Ø 15,9 Ø 22 Ø 25	
	KIPP35-X	35	220	Ø 15,9	A,D
	SKRAP35-X SKRAP50-X	35 50	220 220	Ø 15,9 Ø 25,4	A,D A,D
	SKRAP35 SKRAP50	35 50	220 220	Ø 15,9 Ø 25,4	

Vid order ersŠtt X međ nacktyp (se sid 8)





Tilauksen yhteydessŠ korvaa X niskatyyppillŠ (katso sivu 8)

When ordering replace X by letter for shankgroup (see page 8)

Bei Bestellung bitte das X durch den Buchstaben der Schaftgruppe ersetzen (Sishe 8)

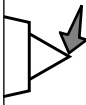
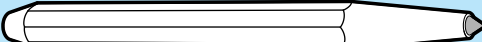
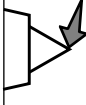
Para hacer su pedido reemplace la X por la letra correspondiente al grupo de bujes (ver pagina 8)

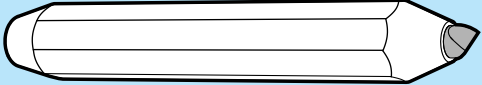
Rebit

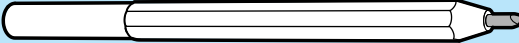
Pik- och spetsmejslar Kivipiikit, kŠrki-ja kŠsitaltat Chisels Meisel, Spitzeisen Cinceles, Punteros	Artikelnr Artikkeli Ordering code Bestell Nr. Producto	Bredd Leveys Width Breite Anchura mm	LŠngd Pituus Length LŠnge Longitud mm	StØeldim. Varsi Steelsize StahlgrŠsse Acero mm	Nackar Niska Shanks Schaftgr. Utilizaci—n
	SPM-X		200	Ø12,7	A,B
	SPM		170	Ø12,7	
	PKM19 PKM22 PKM25	9 9 9	190 190 190	Ø 19 Ø 22 Ø 25	
	DB4S-X	4	210	Ø12,7	A,B

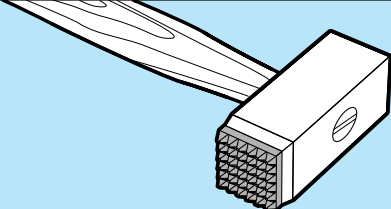
Gradhammare med hØerdmetall Kovametallivasara Busch Hammers (tungsten-carbide) Hartmetallversehene SchrŠghŠmmer Martillo bujarda	Artikelnr Artikkeli Ordering code Bestell Nr. Producto	Huvud PŠŠ Head Kopf Cabeza mm	Antal tŠnder Hamp. lkm No. of teeth Anzahl ZŠhne No. de dientes	LŠngd Pituus Length LŠnge Longitud mm	Vikt Paino Weight Gewicht Peso kg
	GH25K-25T GH35K-36T GH40K-64T	25x25 35x35 40x40	25 36 64	100 110 130	0,4 0,8 1,8

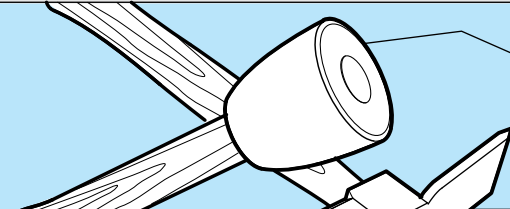
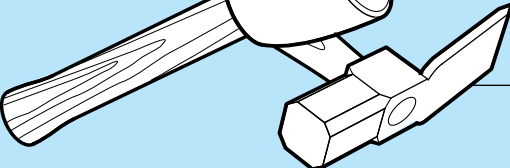
StensŠttarhammare & Portugishammare Asennusvasara Stone-setting Hammer & Roundhammer Steinsetzhammer & Rundhammer Martillo de p na l maza	Artikelnr Artikkeli Ordering code Bestell Nr. Producto	Vikt Paino Weight Gewicht Peso kg
	1031	1,2
	1030	1,1

Vid order ersŠtt X med nacktyp (se sid 8)
Tilauksen yhteydessŠ korvaa X niskatyypillŠ (katso sivu 8)
When ordering replace X by letter for shankgroup (see page 8)
Bei Bestellung bitte das X durch den Buchstaben der Schaftgruppe ersetzen (Sishe 8)
Para hacer su pedido reemplace la X por la letra correspondiente al grupo de bujes (ver pagina 8)

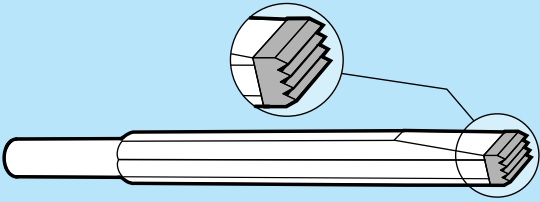
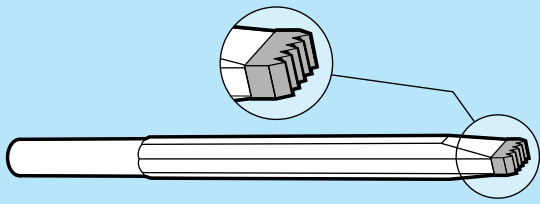
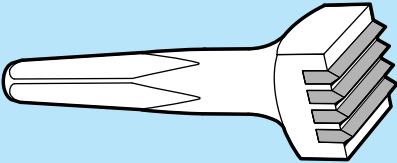
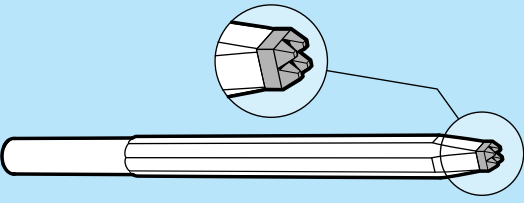
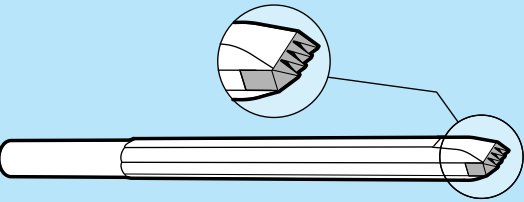
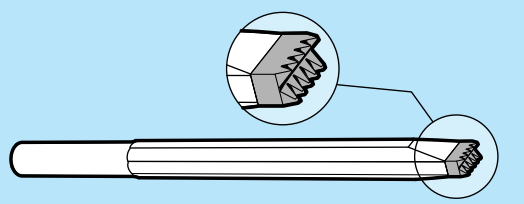
Krysstansar	Artikelnr	Huvud	Antal tSnder	LŠngd	StØl-dim.	Nackar
Rihla-, RistipŠŠ-ja hammastaltat	Artikkeli	PŠŠ	Hamp. lkm	Pituus	Varsi	Niska
Punches	Ordering code	Head	No. of teeth	Length	Steel-size	Shanks
Stanzen	Bestell Nr.	Kopf	Anzahl ZŠhne	LŠnge	Stahlgršsse	Schaftgr.
Martillinas, Trinchantes y Gradinas	Producto	Cabeza mm	No. Dientes	Longit. mm	Acero mm	Utilizaci—n
	RFM-4E-X	10x15	4	185	Ø15,9	A,B
	RFM-5E-X	7x13	5	200	Ø12,7	A,B
	RFM40-4E-X	40x40	4	150	Ø	J,H
	KRS-4T-X KRS-9T-X KRS-16T-X	7x7 7x7 11x11	4 9 16	200 200 200	Ø12,7 Ø12,7 Ø12,7	A,B A,B A,B
	KRM-4T-X	3x12	4	200	Ø12,7	A,B
	TM-10T-X TM-15T-X	6x14 8x14	10 15	200 200	Ø12,7 Ø12,7	A,B A,B

Vid order ersŠtt X med nacktyp (se sid 8)

Tilauksen yhteydessŠ korvaa X niskatyyppiŠ (katso sivu 8)

When ordering replace X by letter for shankgroup (see page 8)

Bei Bestellung bitte das X durch den Buchstaben der Schaftgruppe ersetzen (Sishe 8)

Para hacer su pedido reemplace la X por la letra correspondiente al grupo de bujes (ver pagina 8)

Rebit

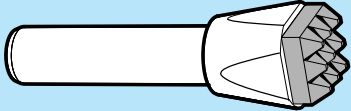
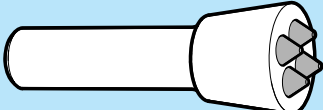
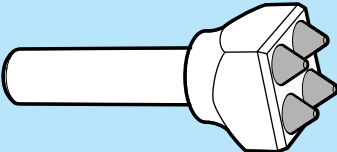
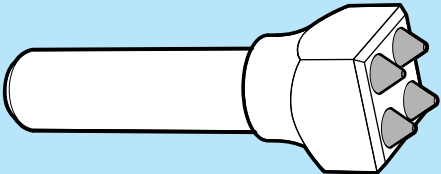
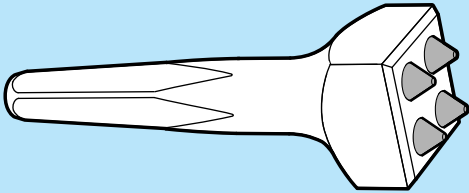
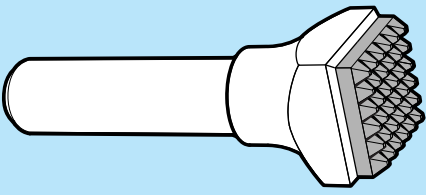
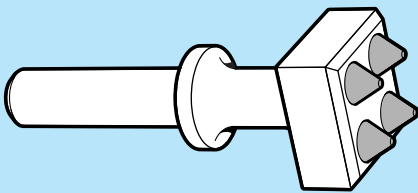
Krysshammare	Artikelnr	Huvud	Antal tSnder	Antal stift	LŠngd	Nackar
Hakkuuvasarat	Artikkeli	PŠŠ	Hamp. lkm	Nast. lkm	Pituus	Niska
Bushhammers	Ordering code	Head	No. of teeth	No. of buttons	Length	Shanks
Stockhammer	Bestell Nr.	Kopf	Anzahl ZŠhne	Anzahl Stifte	LŠnge	Schaftgr.
Bujarda	Producto	Cabeza mm	No. Dientes	No. Botones	Longit. mm	Utilizaci—n
	KHK11-9T-X	11x11	9		~80	A,B
	KHK14-4T-X	14x14	4		~85	A,B,D
	KHK14-9T-X	14x14	9		~85	A,B,D
	KHK14-16T-X	14x14	16		~85	A,B,D
	KHK18-9T-X	18x18	9		~85	A,B,D
	KHK18-16T-X	18x18	16		~85	A,B,D
	KHK18-25T-X	18x18	25		~85	A,B,D
	KHR20-4S-X	~20		4	~70	A,B,D
	KHR35-12S-X	~35		12	~75	A,B,D
	KHK30-4S-X	30x30		4	~85	D
	KHK30-8S-X	30x30		8	~85	D
	KHK30-9S-X	30x30		9	~85	D
	KHK30-16S-X	30x30		16	~85	D
	KHK35-4S-X	35x35		4	~135	E,F,H,J
	KHK35-5S-X	35x35		5	~135	E,F,H,J
	KHK35-9S-X	35x35		9	~135	E,F,H,J
	KHK40-4S-X	40x40		4	110-140	E,F,H,J
	KHK40-9S-X	40x40		9	110-140	E,F,H,J
	KHK40-16S-X	40x40		16	110-140	E,F,H,J
	KHK40-25S-X	40x40		25	110-140	E,F,H,J
	KHK40-36T-X	40x40	36		110-140	E,F,H,J
	KHK40-64T-X	40x40	64		110-140	E,F,H,J
	KHK40-100T-X	40x40	100		110-140	E,F,H,J
	KHK35-4S-X	35x35		4	~110	K,L
	KHK35-8S-X	35x35		8	~110	K,L
	KHK35-9S-X	35x35		9	~110	K,L
	KHK35-16S-X	35x35		16	~110	K,L
	KHK35-64T-X	35x35	64		~110	K,L

Vid order ersŠtt X med nacktyp (se sid 8)

Tilauksen yhteydessŠ korvaa X niskatyyppiŠ (katso sivu 8)

When ordering replace X by letter for shankgroup (see page 8)

Bei Bestellung bitte das X durch den Buchstaben der Schaftgruppe ersetzen (Sishe 8)

Para hacer su pedido reemplace la X por la letra correspondiente al grupo de bujes (ver pagina 8)

Rebit

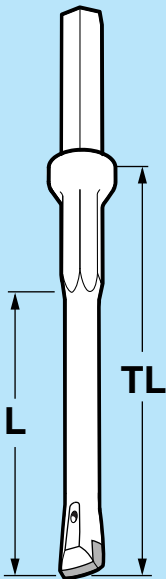
KilhØlsborr	Artikelnr	Breidd	TL	L	Vikt	Nackar
Kiilareikšporat	Artikkeli	Palan leveys			Poino	Niska
Plughole drills	Ordering code	Width			Weight	Shanks
Keillochbohrer	Bestell Nr.	Breite			Gewicht	Schaftgr.
Barrenas Cu-eras	Articulo	Boca mm			Peso kg	Utilizaci—n
		mm	mm			
	721-2117-15	17	210	150	0,6	Ø19x108
	721-2120-15	20	210	150	0,6	
	721-2122-15	22	210	150	0,7	
	721-3120-25	20	310	250	0,9	
	722-2117-15	17	210	150	0,6	Ø19x82,5
	722-2120-15	20	210	150	0,6	
	722-2122-15	22	210	150	0,7	
	722-3120-25	20	310	250	0,9	
	711-2117-15	17	210	150	0,8	Ø22x108
	711-2120-15	20	210	150	0,8	
	711-2122-15	22	210	150	0,9	
	711-3120-25	20	310	250	1,1	
	712-2117-15	17	210	150	0,8	Ø22x82,5
	712-2120-15	20	210	150	0,8	
	712-2122-15	22	210	150	0,9	
	712-3120-25	20	310	250	1,1	

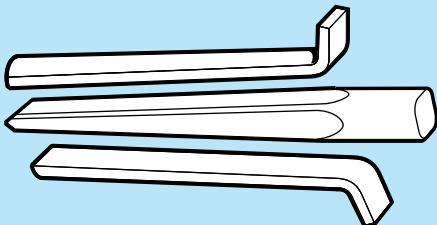
Spršckkiilsatser	Artikelnr	Fšr hØI	Killšngd
Halkaisukiila-sarja	Artikkeli	Reikškoko	Kiilapituus
Plug and pair of feathers	Ordering code	For hole	Wedge length
Brechkeilgarnitur	Bestell Nr.	FŸr Lšcher	Keillšnge
Cu-as	Art'culo	Para diametro	Longitud
		mm	mm
	2041-2042	34	420
	2091-2092	29	390
	2051-2052	24	150
	2071-2072	20-22	180

Nackar Niskat Shanks Shaftgruppen Utilizacio'n

A

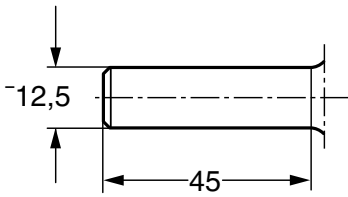

REBIT BHV 12, BHV 16, BHV 22

B

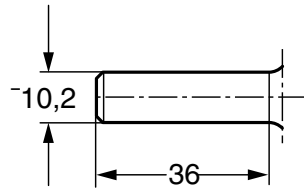

FROLICH-KLUPFEL

D

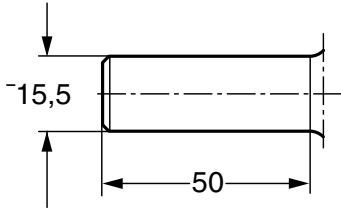

REBIT BHV 26

E

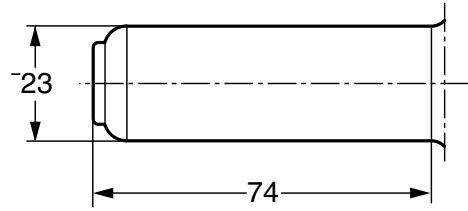

REBIT BHV 30

F

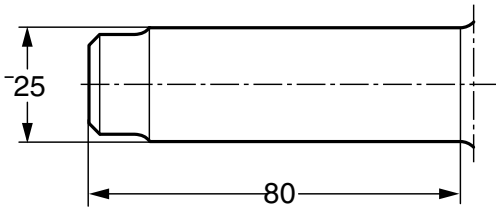

ATLAS COPCO KV 434

H

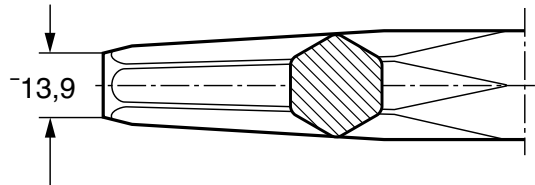

B...HLER (E13.9),M40,M50,M60K,KL69,KL70

J

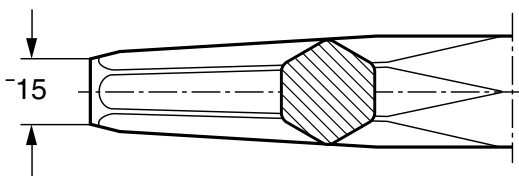

B...HLER (E115),M40,M50,M60K,KL69,KL70

K

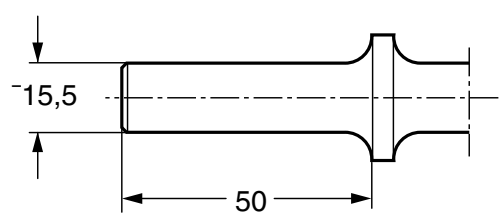

PELLEGRINI

L

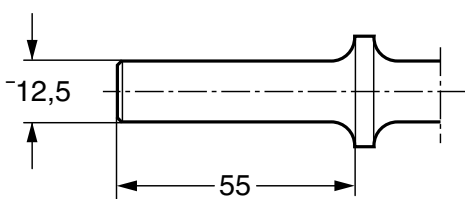

PELLEGRINI

Q

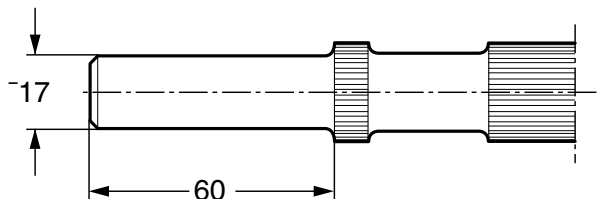

ATLAS COPCO RRD 37-57

Vid order ersätt X med nacktyp
 Tilauksen yhteydessä korvaa X niskatyyppiä
 When ordering replace X by letter for shankgroup
 Bei Bestellung bitte das X durch den Buchstaben der Schaftgruppe ersetzen
 Para hacer su pedido reemplace la X por la letra correspondiente al grupo de bujes

BHV-Hammare
BHV-Hakkuuvasara
BHV-Stone-Worker
BHV-Stockhammer
BHV-Martillos

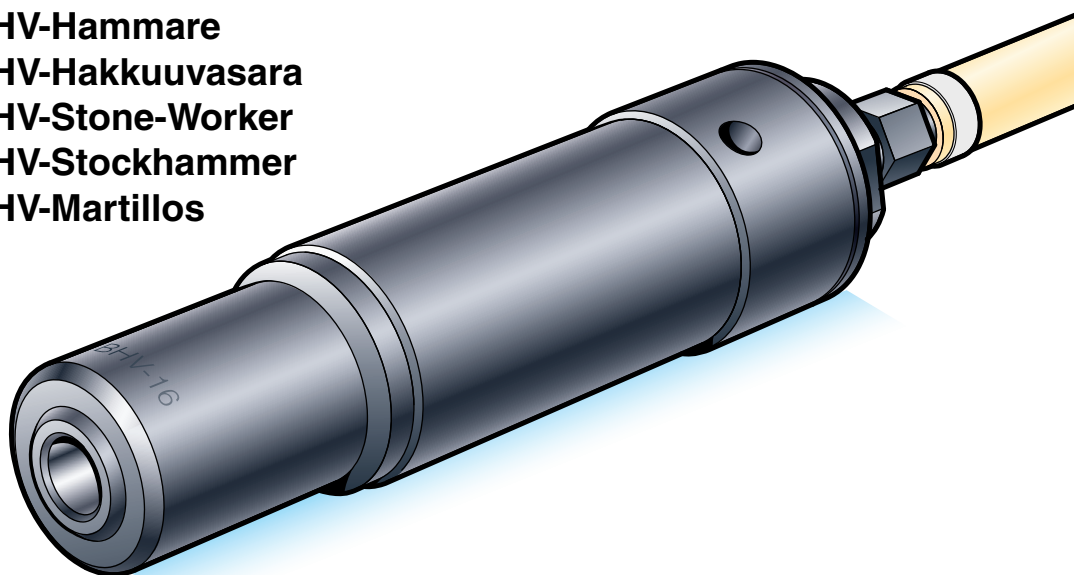

Artikelnr	Kolv diameter	Slag- lSngd	Slag per min	Luftšrbrukn. vid 6-7 bar	LŠngd	Vikt	Slang- diameter	Nack- diameter
Artikkeli	MŠnnŠn halk.	Isku- pituus	Isku luku	Ilmankulutus 6-7 bar	Pituus	Paino	Letkun	Niska
Ordering code	Piston dia.	Stroke lenght	Stroke per min	Air consumpt. at 6-7 bar	Length	Weigth	Tube dia.	Shank
Bestell Nr.	Kolben durchm.	Schlag- lSnge	Schlag- zahlpro min	Luftverbrauch bei 6-7 bar	LŠnge	Gewicht	Schlauch Durchm.	Shaft Durchm.
Producto	Diametro piston mm	Carrera mm	Frecuencia de impactos	Consumo de aire 6-7 bar m3/min	Longitud mm	Peso kg	Diametro del mart. mm	Buje mm
BHV 12	12	24	6 500	0,15	150	0,7	9,5	12,6 x 47
BHV 16	16	27	5 600	0,20	165	0,9	9,5	12,6 x 47
BHV 22	22	30	5 000	0,25	185	1,4	9,5	12,6 x 47
BHV 26	26	35	4 000	0.40	205	2,0	9,5	15,7 x 47

Rebit

Rebit AB, HamrCengev.25 816 31 OCKELBO, SWEDEN. 46-(0)297-557 70 . FAX 46-(0)297-425 00